

EP211 SERIES

ELECTRIC DRIVEN HYDRAULIC PUMP

SINGLE & DOUBLE ACTING MODELS

1½ HP, 1 PHASE, 9.5 LITRES CAPACITY

MAX PRESSURE: 10,000psi/700Bar



EP211

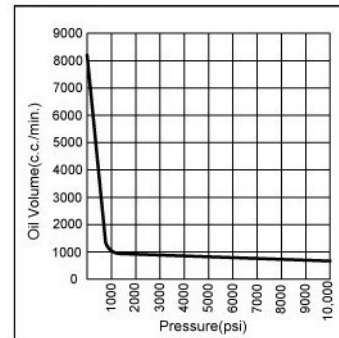

FEATURES

- Original pumps are built with 1 1/2 HP, 220V, 50/60Hz, Single phases universal brushless motor.
- Internal relief valve (700 bars) protects the components and work safety.
- Pumps are included with 24V, 3 meters remote control cord.
- Quiet pumps comply OSHA noise limitation (80dBA at 700bar).
- EP211D specially designed for double-acting cylinders without the need for additional control valve and adapters.
- Conform to CE standards.
- Both models are available with Solenoid Valve version.

MODEL:EP211S

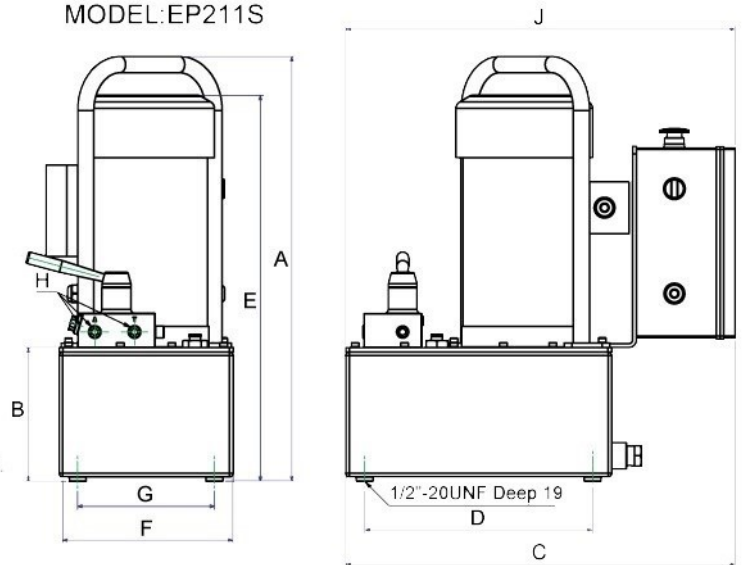

Model No.	Acting	RPM 50/60 Hz	Reservoir Capacity (c.c.)	Usable Oil Capacity (c.c.)	Motor	Max. Pressure Output (psi)	Valve		Oil Del. (c.c./min.@)*(60Hz)			
							Type	Function	0(psi)	100(psi)	5000(psi)	10000(psi)
EP211S	Single	2860 / 3450	11,000	9,500	1.12 KW 110V / 220V 50 / 60 Hz	10,000	2 Position / 2 Way	Hold /Retract	8,200	7,400	840	750
EP211D												
EP211DS*	Double	2860 / 3450	11,000	9,500	Single Phase	10,000	3 Position / 4 Way	Adv./Hold /Retract	8,200	7,400	840	750

Model No.	A (mm)	B (mm)	C (mm)	D (mm)	E (mm)	F (mm)	G (mm)	H	J (mm)	Weight (kg)
EP211 Series	559	176	515.5	300	391.5	224.4	180	3/8"-NPT	515.5	40

* Solenoid Valve version.

** The weight is excluding the hydraulic oil.